

NEVER STOPPING.

NEVER SETTling.



It's Hard To Stop A Trane.®

NEVER STOPPING. NEVER SETTLING.

Trane Product Update Call



It's Hard To Stop A Trane.®

December 2018

- **Product Updates and Managers:**
 - Air Conditioner – Jim Lowell
 - Heat Pump – Tim Storm
 - Furnace – Mark Woodruff
 - Coils –Patrick Van Deventer
 - Geothermal and Indoor Air Quality – Jay Ayers
 - Controls – Karl Mutchnik
 - Residential Packaged – Charles Trammell
 - Light Commercial Packaged – Matt Bynum
 - Air Handlers – Dave Garris
 - Ductless – Tai McKinney
 - Ameristar – Brian Steckroth
 - Closing Comments

NEVER STOPPING. NEVER SETTLING.

Air Conditioner – Jim Lowell



It's Hard To Stop A Trane.®

XL18i (4 ton) and XR17 (4 ton) Air Conditioner Improvements

- New, more efficient Climatuff™ 2 stage compressor
- New ECM 2 speed fan motor
- Elimination of the Desuperheater coil:
 - Lighter weight - easier to install
 - Fewer brazed joints - improved reliability
- (96) existing system matches have improved ratings (sample ratings shown below)
- Over 200 new system ratings added – finding the exact match you need is easier
- Energy Star certified

| Sample Ratings | | OLD | | | NEW | | | |
|----------------|------------------|---------------|------|-------|----------|------|------|----------|
| | Coil | Furnace | SEER | EER | Capacity | SEER | EER | Capacity |
| 2 Stage AC, 4t | 4TXCC007DS3 | N/A | 15 | 12 | 46000 | 15 | 12.5 | 47000 |
| | 4TXCB006DS3 | S9X2B080U4PSA | 16 | 12.5 | 48000 | 17 | 12.5 | 47000 |
| | 4PX*BU48BS3 | S9V2B060U4PSB | 16 | 13 | 47500 | 17 | 13 | 45000 |
| | 4PX*CU48BS3 | *UD2C080A9V4 | 16.5 | 12.75 | 48000 | 17 | 13 | 47000 |
| | TEM8A0D48V41+TDR | N/A | 16 | 13 | 48500 | 17 | 13 | 47000 |



Trane **WeatherGuard** Top Kit

Available Q2 2019

- *Easy to install*
- *Retrofittable to all split AC's and HP's with plastic base pan (since approx. 2001)*
- *Protects unit from debris, snow, ice*
- *Looks great!*
- *Newly designed top will be phased into production for current XLi and XVi products during Q1*



NEVER STOPPING. NEVER SETTLING.

Heat Pump – Tim Storm



It's Hard To Stop A Trane.®

AHRI Failure on Simulated Dual Fuel System (4TWX824A/4TWR7024A/4PXCBU36BS3/TUHMB080)

- We will be introducing new XR17 and XL18i 2 ton heat pump models as a result of an AHRI failure on an dual fuel simulation.
 - The HSPF was less than 95% of the published efficiency
 - The SEER and EER met the published AHRI rating
- The HSVTC tested combinations with the TAM7-30 air handlers passed with flying colors
- To minimize risk of failing additional testing in 2019 , we will be introducing a new 4TWR7024**B**1000A and 4TWX8024**B**1000A model the first week of January and phasing out the current "A" models. A bulletin on the new model with AHRI ratings will be issued the week of December 10th.

NEVER STOPPING. NEVER SETTLING.

Furnace – Mark Woodruff



It's Hard To Stop A Trane.®

S8X1 & S8X2 Are Here!

- Short 34" Height
- 80% AFUE, 4-way multi-poise
- Dealer Guide & Introduction Document is Available!
 - Samples are coming in the mail!
 - **PUB. No. 62-7233-01** ← *Order This!*

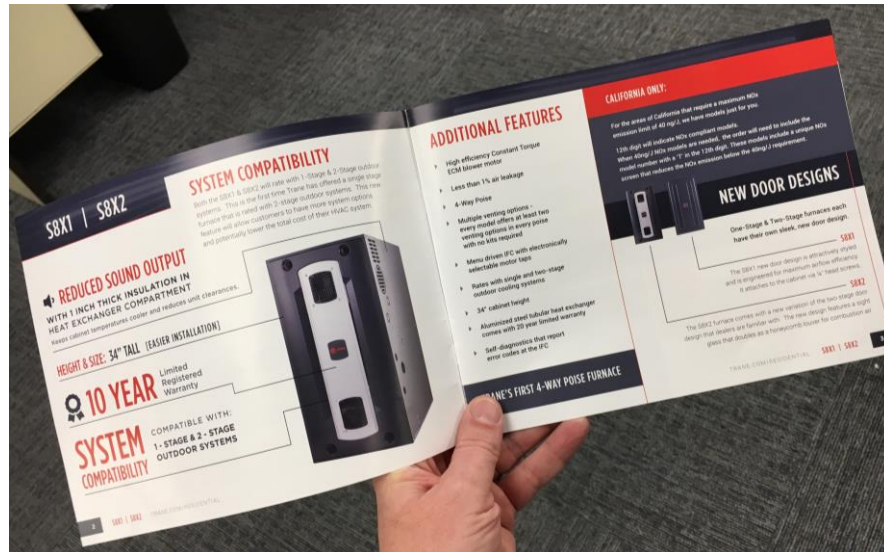

Important Dates:

- 1st Prod: Nov 30th
- 1st Ship: Dec 17th
- Legacy Last Order: Nov 19th
- Legacy Last Prod: Dec. 3rd

Dealer Guide: PUB. No. 62-7233-01



S8X1 | S8X2

SYSTEM COMPATIBILITY

Both the S8X1 & S8X2 will rate with 1-Stage & 2-Stage outdoor systems. This is the first time Trane has offered a single stage furnace that is rated with 2-stage outdoor systems. This new feature will allow customers to have more system options and potentially lower the total cost of their HVAC system.

REDUCED SOUND OUTPUT
WITH 1 INCH THICK INSULATION IN HEAT EXCHANGER COMPARTMENT
Keeps cabinet temperatures cooler and reduces unit clearances.

HEIGHT & SIZE: 34" TALL [EASIER INSTALLATION]

10 YEAR Limited Registered Warranty

SYSTEM COMPATIBILITY COMPATIBLE WITH:
1 - STAGE & 2 - STAGE OUTDOOR SYSTEMS

The image shows a Trane S8X1 or S8X2 furnace unit, a tall, rectangular, dark-colored cabinet with a silver front panel. The front panel features a central control panel with a red indicator light and two circular vents. The unit is shown from a three-quarter perspective, highlighting its compact and modern design. Lines connect the text blocks to specific features of the unit, such as the top and bottom vents and the central control panel.

Dealer Guide: PUB. No. 62-7233-01



ADDITIONAL FEATURES

- ▶ High efficiency Constant Torque ECM blower motor
- ▶ Less than 1% air leakage
- ▶ 4-Way Poise
- ▶ Multiple venting options - every model offers at least two venting options in every poise with no kits required
- ▶ Menu driven IFC with electronically selectable motor taps
- ▶ Rates with single and two-stage outdoor cooling systems
- ▶ 34" cabinet height
- ▶ Aluminized steel tubular heat exchanger comes with 20 year registered limited warranty
- ▶ Self-diagnostics that report error codes at the IFC

TRANE'S FIRST 4-WAY POISE FURNACE

CALIFORNIA ONLY:

For the areas of California that require a maximum NOx emission limit of 40 ng/J, we have models just for you.

12th digit will indicate NOx compliant models.

When 40ng/J NOx models are needed, the order will need to include the model number with a 'T' in the 12th digit. These models include a unique NOx screen that reduces the NOx emission below the 40ng/J requirement.



NEW DOOR DESIGNS

One-Stage & Two-Stage furnaces each have their own sleek, new door design.

S8X1

The S8X1 new door design is attractively styled and is engineered for maximum airflow efficiency. It attaches to the cabinet via ¼" head screws.

S8X2

The S8X2 furnace comes with a new variation of the two stage door design that dealers are familiar with. The new design features a sight glass that doubles as a honeycomb louver for combustion air.

TRANE.COM/RESIDENTIAL **S8X1 | S8X2**

3

Dealer Guide: PUB. No. 62-7233-01



NEW METAL VORTICA™ II

Both S8X1 & S8X2 will launch using our new patented Vortica™ II blower design that is constructed of steel rather than composite.

HIGHLIGHTS

- ✓ Durable & recyclable steel construction
- ✓ Patented design
- ✓ Swept surface design uses less energy than conventional blowers
- ✓ Compact
- ✓ Easy to service with self-aligning rails that extend all the way to the front of the bottom compartment.
- ✓ Integral belly band motor arms
- ✓ Unique 9 tap motor offers industry leading customized & optimized airflow options



SMALL SIZE, BIG IMPACT

LOW-CAPACITY FURNACES ARE THE NEXT BIG THING

As housing becomes smaller and more energy efficient, Trane is introducing new and lower capacity furnaces to market. At just **14.5 inches wide** and **34 inches tall**, these furnaces are the perfect size for small multi-family homes and condos where space is a premium. The S8X1 offers 26,000 BTU/h options and the S8X2 offers a 40,000 BTU/h option which fires at 26,000 BTU/h on low stage.



4

S8X1 | S8X2

TRANE.COM/RESIDENTIAL

Dealer Guide: PUB. No. 62-7233-01



MORE OPTIONS, FEWER SKU'S

The new S8X1 & S8X2 furnaces come equipped with **9-tap constant torque ECM blower motors**. These blowers offer a greater range of operation, making it possible in some cases to **cover multiple cooling tonnages** with a single model. This reduces the number of models that dealers and distributors manage and inventory in their warehouse.



Each of our 9 taps is **electronically selectable** via our menu driven IFC and LED display. With legacy furnaces, the system must be shut down, and motor taps must be physically moved and rewired on the control board before the system can be restarted. Our new design allows both heating and cooling airflows to be adjusted on the fly, which makes checking temperature rise or cooling airflow easier than ever before.

S8X1

S8X2

| SKU | NOMINAL AIRFLOW (TONS) |
|----------------|------------------------|
| S8X1A026M2PSAA | 2 |
| S8X1A040M3PSAA | 2-3 |
| S8X1B040M2PSAA | 2 |
| S8X1B060M3PSAA | 3 |
| S8X1B060M4PSAA | 4 |
| S8X1B080M4PSAA | 3-4 |
| S8X1C080M5PSAA | 4-5 |
| S8X1C100M5PSAA | 4-5 |
| S8X1D120M5PSAA | 5 |
| S8X2A040M3PSAA | 2-3 |
| S8X2B060M3PSAA | 3 |
| S8X2B060M4PSAA | 4 |
| S8X2B080M4PSAA | 3-4 |
| S8X2C080M5PSAA | 4-5 |
| S8X2C100M5PSAA | 4-5 |
| S8X2D120M5PSAA | 5 |

Dealer Guide: PUB. No. 62-7233-01



| FEATURES | S8X1 | S8X2 |
|---|-------------------|------------------|
| Gas Stages | Single Stage Heat | Two Stage Heat |
| Heating Input | 26K - 120K BTU/h | 40K - 120K BTU/h |
| High Efficiency constant torque ECM blower motor | ✓ | ✓ |
| Certified to <1% air leakage | ✓ | ✓ |
| 4-Way Poise Convertibility | ✓ | ✓ |
| Multiple venting option - every model offers at least two venting options in every poise | ✓ | ✓ |
| Menu driven IFC with electronically selectable motor taps | ✓ | ✓ |
| Self-diagnostics that report error codes at the IFC | ✓ | ✓ |
| No Dip Switches | ✓ | ✓ |
| Rates with single and two-stage outdoor cooling systems | ✓ | ✓ |
| 34" cabinet height | ✓ | ✓ |
| IFC digital display characters can be rotated, making the display easier to read in down-flow applications where the display would normally be upside down. | ✓ | ✓ |
| Aluminized steel tubular heat exchanger comes with 20 year registered limited warranty. | ✓ | ✓ |
| Menu Driven Seven Segment IFC Display | ✓ | ✓ |
| Easy System Setup | ✓ | ✓ |
| Blower compartment insulation (Excluding "A" cabinet widths) | ✓ | ✓ |
| Appliance-like Door | ✓ | ✓ |
| Metal Vortica™ II | ✓ | ✓ |
| Forward Facing Screws for Component Servicing | ✓ | ✓ |

Dealer Guide: PUB. No. 62-7233-01



| | | FULL ACCESSORY KIT LIST | |
|----------------|---|--|---|
| MODEL NUMBER | DESCRIPTION | USE WITH: | |
| BAYHANG | Horizontal Hanging Kit | All Furnaces | |
| BAYLIFTB | Dual Return Kit (B Size extension) | B Cabinet Furnaces | |
| BAYLIFTC | Dual Return Kit (C Size extension) | C Cabinet Furnaces | |
| BAYLIFTD | Dual Return Kit (D Size extension) | D Cabinet Furnaces | |
| BAYBASE205 | Downflow Subbase | All Furnaces in Downflow Orientation | |
| BAYFLTR206 | Filter Access Door Kit (Downflow Only) | All Furnaces in Downflow Orientation | |
| BAYSF1165AA | 1" SlimFit Box with MERV 4 filter | All Furnaces | |
| BAYFLTR203 | Horizontal Filter Kit | B Cabinet Furnaces in Downflow/Horizontal | |
| BAYFLTR204 | Horizontal Filter Kit | C Cabinet Furnaces in Downflow/Horizontal | |
| BAYFLTR205 | Horizontal Filter Kit | D Cabinet Furnaces in Downflow/Horizontal | |
| BAYVENT600A | Internal Venting Kit | B, C, and D Furnaces in Downflow orientation | |
| BAYVENT800B | Masonry Chimney Vent Kit | All Furnaces | |
| BAYSWT13AHALTA | High Altitude Pressure Switch Kit | S8X1A026M2PSAA | |
| BAYSWT14AHALTA | High Altitude Pressure Switch Kit | S8X1A040M3PSAA, S8X1B040M2PSAA, S8X1C080M5PSAA, S8X1C100M5PSAA | |
| BAYSWT15AHALTA | High Altitude Pressure Switch Kit | S8X1B060M3PSAA, S8X1B060M4PSAA, S8X1B080M4PSAA | |
| BAYSWT16AHALTA | High Altitude Pressure Switch Kit | S8X2A040M3PSAA, S8X2C080M5PSAA | |
| BAYSWT17AHALTA | High Altitude Pressure Switch Kit | S8X2B060M3PSAA, S8X2B060M4PSAA | |
| BAYSWT18AHALTA | High Altitude Pressure Switch Kit | S8X2B080M4PSAA | |
| BAYSWT19AHALTA | High Altitude Pressure Switch Kit | S8X2C100M5PSAA | |
| BAYLPSS400B | Propane Conversion Kit with Stainless Steel Burners | All Furnaces except S8X1A026 | |
| BAYLPSS410A | Propane Conversion Kit with Stainless Steel Burners | S8X1A026 Furnace only | |
| PIP02095 | U Fitting for gas piping | All Furnaces for right hand gas entry | 7 |

Dealer Guide: PUB. No. 62-7233-01



FREQUENTLY ASKED QUESTIONS

- 1. Are these furnaces compatible with LP (Propane)?**
Yes, and propane kits are available. When converted to propane, S8 furnaces will have similar sound characteristics as S9 furnaces, which can be a consideration for noise sensitive applications.
- 2. Are they rated with 1-stage and 2-stage outdoor systems?**
Yes – both S8X1 & S8X2 are rated with both 1-stage and 2-stage outdoor systems. This is the first time we have ever had single stage furnaces matched with 2-stage outdoor systems, which offers new opportunities for our customers.
- 3. What is the firing rate for each furnace?**
The low-stage firing rate is 65%, and the high-stage firing rate is 100% (Max), except for the 120 BTU models which have a firing rate of Low 70% - High 100% (max).
- 4. Does the S8X1A026 only have one burner tube?**
No, it has two tubes and fires at 13 BTU/h per tube.
- 5. Can the unit be set up for left or right side gas entry?**
Yes, every furnace is shipped ready for default left side gas entry (in up-flow), and default right side gas entry for down-flow. Gas entry through the alternate side is possible via optional accessory part PIP02095.
- 6. Do they meet air leakage requirements?**
Yes, these furnaces are AirTite™, meaning they are rated to <1% air leakage.

- 7. What is the clearance to combustibles?**

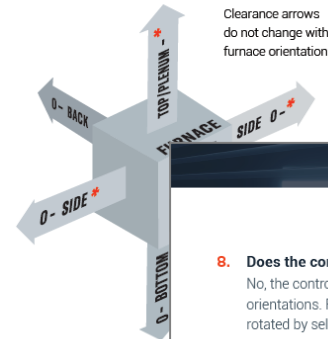

* FOR HORIZONTAL APPLICATIONS

- 14.5" Cabinets, 1" Sides & 2" Top
- 17.5" Cabinets, 1" Sides & 2" Top
- 21.0" Cabinets, 1" Sides & 3" Top
- 24.5" Cabinets, 1" Sides & 5" Top

Line contact only permissible between lines and two sides of the furnace jacket, and but

8

S8X1 | S8X2 TRANE.COM/RESIDENTIAL

Two Pages of FAQ's!!

- 8. Does the control have to be rotated when used in downflow?**
No, the control does not have to be removed or reoriented for different orientations. For down-flow, the LED 7-segment display text can be rotated by selecting 'UP' or 'DN' in the "ORN" menu.
- 9. Do these furnaces use the Vortica blower?**
Yes, these furnaces use the first steel Vortica blowers, produced at our factory in Trenton, NJ. The new steel Vortica design has patented technology, and has the same industry leading efficiency as the composite design.
- 10. Do the new blower motors really have 9 speed taps?**
Yes, as airflow efficiency becomes more and more important, our new ECM motors have 9 speed taps, electronically selectable through the IFC. These new motors have many benefits, one of them is that they can cover a wider range of airflows, and in some cases have allowed us to reduce the number of unique SKU's that are required.
- 11. Are there California compliant 40 ng/J low-NOx SKU's available?**
Yes, a 'T' in digit 12 indicates that model is a 40 ng/J low-NOx model, and complies with California NOx manufacturer requirements.
- 12. Can these furnaces be twinned?**
Yes, all models can be twinned. Instructions and wiring diagrams are located in the Installers Guide.
- 13. What size circuit breaker is required on these models?**
All models require only 15 Amp breakers! This helps save time and money on many retrofit/replacement applications.
- 14. Are these furnaces 4-way convertible (multi-raise)?**
Yes! Every model can be converted or installed in all 4 positions, and no kits are needed for any of the positions. Venting through the cabinet in downflow orientation requires BAYVENT600A. See graphic below.

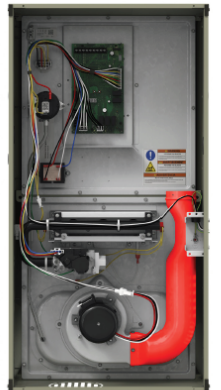

DOWNFLOW ADAPTER IN PLACE

Accessory kit BAYVENT600A required for internal cabinet venting in downflow.

TRANE.COM/RESIDENTIAL S8X1 | S8X2

9

Dealer Guide: PUB. No. 62-7233-01



| Outdoor Family | Outdoor Model # | Coil Model # | Furnace Model | Capacity (95F) | SEER | EER | HSPF |
|-------------------------------|---------------------------|---------------------------|--------------------|----------------|------|------|------|
| XR16 / XL16 (Single-Stage) | 4TT(RX)G018J1000AA | 4PXCAU24BS3 / 4TXCA002DS3 | S8X(1,2)A040M3PSAA | 18400 | 1G | 14 | |
| | 4TT(RX)G018J1000AA | 4PXCAU24BS3 / 4TXCA002DS3 | S8X1A026M2PSAA | 18500 | 1G | 14 | |
| | 4TT(RX)G018J1000AA | 4PXCBU30BS3 / 4TXCB003DS3 | S8X(1,2)B040M2PSAA | 19100 | 17 | 14 | |
| | 4TT(RX)G024J1000AA | 4PXCBU30BS3 / 4TXCB003DS3 | S8X(1,2)B040M2PSAA | 24400 | 1G | 14 | |
| | 4TT(RX)G030J1000AA | 4PXCBU30BS3 / 4TXCB003DS3 | S8X(1,2)B060M3PSAA | 29400 | 1G | 13.5 | |
| | 4TT(RX)G030J1000AA | 4PXCCU30BS3 | S8X(1,2)C080M5PSAA | 29600 | 1G | 13.5 | |
| | 4TT(RX)G036J1000AA | 4PXCBU36BS3 / 4TXCB004DS3 | S8X(1,2)B060M3PSAA | 35200 | 1G | 14 | |
| | 4TT(RX)G036J1000AA | 4PXCCU36BS3 / 4TXCC005DS3 | S8X(1,2)C080M5PSAA | | | | |
| | 4TT(RX)G036J1000AA | 4PXCBU36BS3 / 4TXCB004DS3 | S8X(1,2)B080M4PSAA | | | | |
| | 4TTXG042J1000AA | 4PXCBU42BS3 | S8X(1,2)B060M4PSAA | | | | |
| | 4TTXG042J1000AA | 4PXCBU48BS3 / 4TXCB006DS3 | S8X(1,2)B060M4PSAA | | | | |
| | 4TTXG042J1000AA | 4PXCBU42BS3 | S8X(1,2)B080M4PSAA | | | | |
| | 4TTXG042J1000AA | 4PXCBU48BS3 / 4TXCB006DS3 | S8X(1,2)B080M4PSAA | | | | |
| | 4TTXG042J1000AA | 4PXCBU36BS3 / 4TXCC005DS3 | S8X(1,2)C080M5PSAA | | | | |
| | 4TTXG042J1000AA | 4PXCCU36BS3 / 4TXCC005DS3 | S8X(1,2)C100M5PSAA | | | | |
| | 4TTXG042J1000AA | 4PXCDU48BS3 / 4TXCD008DS3 | S8X(1,2)D120M5PSAA | | | | |
| | 4TTXG049J1000AA | 4PXCCU48BS3 / 4TXCC007DS3 | S8X(1,2)C100M5PSAA | | | | |
| | 4TTXG049J1000AA | 4PXCBU48BS3 / 4TXCB006DS3 | S8X(1,2)B080M4PSAA | | | | |
| 4TTXG049J1000AA | 4PXCCU48BS3 / 4TXCC007DS3 | S8X(1,2)C100M5PSAA | | | | | |
| 4TTXG049J1000AA | 4PXCDU48BS3 / 4TXCD008DS3 | S8X(1,2)D120M5PSAA | | | | | |
| 4TTXG061J1000AA | 4PXCDU60BS3 / 4TXCD010DS3 | S8X(1,2)C100M5PSAA | | | | | |

Ratings above are preliminary. Visit AHRI.directory.org for final published ratings.

10 AHRI RATINGS | XR16 / XL16 (SINGLE-STAGE) TRANE.COM/RESIDENTIAL

Two Pages of Ratings!!

| Outdoor Family | Outdoor Model # | Coil Model # | Furnace Model | Capacity (95F) | SEER | EER | HSPF | |
|--------------------------------|-----------------|---------------------------|--------------------|----------------|------|------|------|-----|
| XR16 (Single-Stage) | 4TTRG042J1000AA | 4PXCCU48BS3 / 4TXCC007DS3 | S8X(1,2)C080M5PSAA | 41000 | 1G | 13.5 | N/A | |
| | 4TTRG042J1000AA | 4PXCDU48BS3 / 4TXCD008DS3 | S8X(1,2)D120M5PSAA | 41500 | 1G | 14 | | |
| | 4TTRG048J1000AA | 4PXCUG06BS3 / 4TXCC009DS3 | S8X(1,2)C100M5PSAA | 47000 | 1G | 13.5 | | |
| | 4TTRG048J1000AA | 4PXCDU60BS3 / 4TXCD010DS3 | S8X(1,2)D120M5PSAA | 48000 | 1G | 13.5 | | |
| | 4TTRG061C1000AA | 4PXCCU60BS3 / 4TXCC009DS3 | S8X(1,2)C100M5PSAA | 57000 | 1G | 13 | | |
| | 4TTR4018L1000AA | 4PXCBU30BS3 / 4TXCB003DS3 | S8X(1,2)B040M2PSAA | 19000 | 1G | 13.6 | | |
| XR14 (Single-Stage) | 4TTR4025L1000AA | 4PXCBU30BS3 / 4TXCB003DS3 | S8X(1,2)B060M3PSAA | 24000 | 1G | 13 | N/A | |
| | 4TTR4031L1000AA | 4PXCBU36BS3 / 4TXCB004DS3 | S8X(1,2)B060M3PSAA | 29000 | 1G | 13 | | |
| | 4TTR4037L1000AA | 4PXCBU48BS3 / 4TXCB006DS3 | S8X(1,2)B060M3PSAA | 35000 | 1G | 13 | | |
| | 4TTR4037L1000AA | 4PXCCU48BS3 / 4TXCC007DS3 | S8X(1,2)C080M5PSAA | 35000 | 1G | 13 | | |
| | 4TTR4037L1000AA | 4PXCBU30BS3 / 4TXCB003DS3 | S8X(1,2)B040M2PSAA | 25000 | 17 | 13.5 | | |
| | 4TTR4037L1000AA | 4PXCBU48BS3 / 4TXCB006DS3 | S8X(1,2)B060M3PSAA | 37200 | 17 | 13 | | |
| XL18 AC & HP (Two-Stage) | 4TTR4037L1000AA | 4PXCBU48BS3 / 4TXCB006DS3 | S8X(1,2)B080M4PSAA | 37200 | 17 | 13 | N/A | |
| | 4TTR4040B1000AA | 4PXCCU60BS3 / 4TXCC009DS3 | S8X(1,2)C100M5PSAA | 48000 | 17 | 13 | | |
| | 4TTR4040B1000AA | 4PXCDU60BS3 / 4TXCD010DS3 | S8X(1,2)D120M5PSAA | 49500 | 18 | 13 | | |
| | 4TTR4060A1000AA | 4PXCCU60BS3 / 4TXCC010DS3 | S8X(1,2)D120M5PSAA | 57500 | 1G | 13 | | |
| | 4TTR4060A1000AA | 4PXCBU30BS3 / 4TXCB003DS3 | S8X(1,2)B060M3PSAA | 25600 | 17 | 13 | | 9.5 |
| | 4TTR4060A1000AA | 4PXCBU36BS3 / 4TXCB004DS3 | S8X(1,2)B080M4PSAA | 36000 | 17 | 13 | | 9 |
| | 4TTR4060A1000AA | 4PXCBU48BS3 / 4TXCB006DS3 | S8X(1,2)B060M4PSAA | 37000 | 18 | 13 | | 9 |
| | 4TTR4060A1000AA | 4PXCCU60BS3 / 4TXCC009DS3 | S8X(1,2)C100M5PSAA | 48500 | 17 | 13 | | 9 |
| | 4TTR4060A1000AA | 4PXCCU60BS3 / 4TXCC009DS3 | S8X(1,2)C100M5PSAA | 56000 | 1G | 11.5 | | 9 |
| | 4TTR4060A1000AA | 4PXCDU60BS3 / 4TXCD010DS3 | S8X(1,2)D120M5PSAA | 57000 | 1G | 11.5 | | 9 |

Ratings above are preliminary. Visit AHRI.directory.org for final published ratings.

TRANE.COM/RESIDENTIAL AHRI RATINGS | XR16/XR14 (SINGLE-STAGE) | XL18 AC & HP (TWO-STAGE)

11

Dealer Guide: PUB. No. 62-7233-01

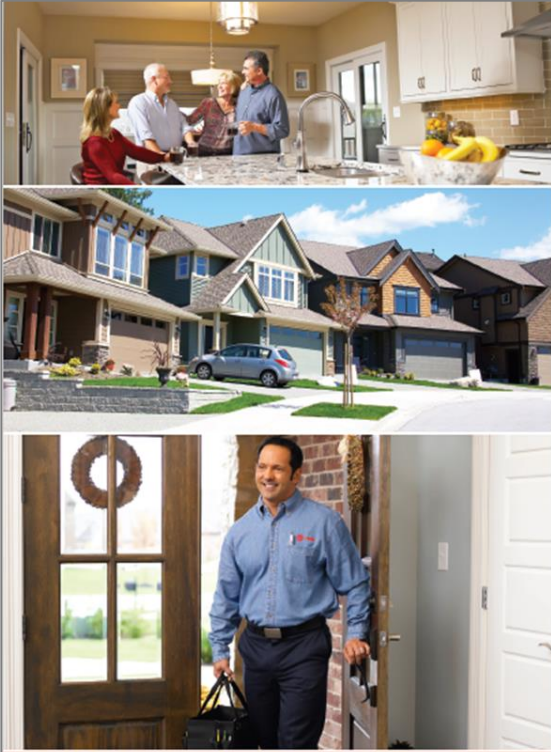

RESIDENTIAL BASE LIMITED WARRANTY
Parts: 5 years | Heat Exchanger: 20 years

RESIDENTIAL REGISTERED LIMITED WARRANTY
Parts: 10 years | Heat Exchanger: 20 years

FIELDTECHHELP.COM

For helpful installation and service information, tutorial videos, and more.

This guide is for informational purposes only. Trane believes the facts and suggestions presented here to be accurate. However, final design and application decisions are your responsibility.

PUB. No. 62-7233-01



It's Hard To Stop A Trane.

10-MEQUI-1345-50X1/50X2 Product Launch Booklet

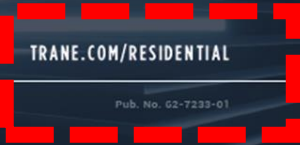

Pub. No. 62-7233-01

Furnace Product Launches 2019

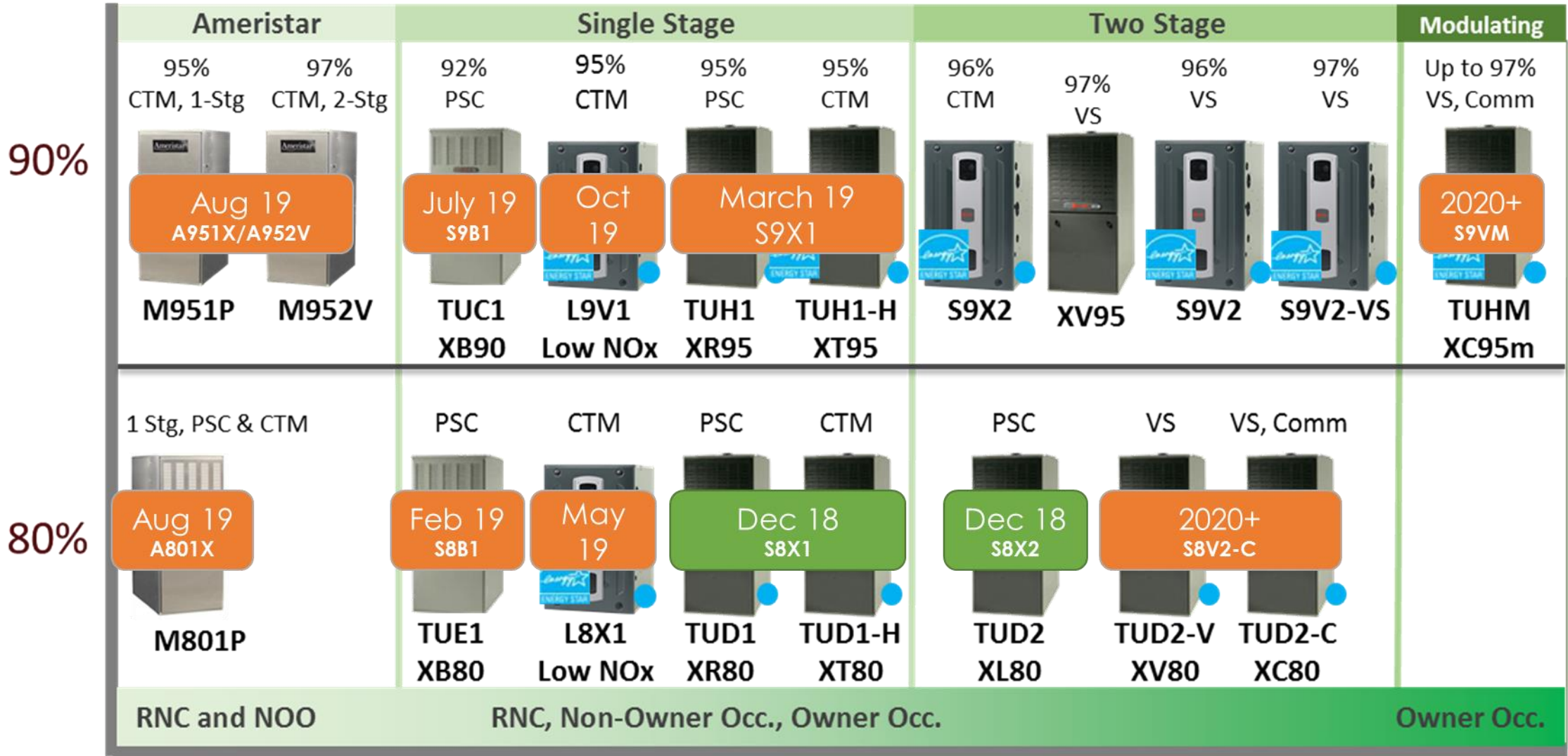

● Certified <2% air leakage

FER Update

- July 3, 2019 is fast approaching!
- Trane FER compliant furnaces are rolling out!
 - CTM Motors
 - CTM capable controls (IFC)
 - CTM wiring harnesses
 - Vortica II™ blowers
 - Higher horsepower motors
 - Wider & larger diameter blower housings and blower wheels
- Must prepare customers!

1

A very important ruling from the Department of Energy:

FER
(Fan Efficiency Rating)



Dr. Ernst J. Moniz
Former US Secretary of Energy
(Department of Energy/DOE)



2

What Does It Do?

- FER (Fan Energy Rating)
 - Sets limits for airflow efficiency in Residential Furnaces (& Pkg units)
 - Designed to eliminate PSC blower motors
 - Designed to eliminate single stage heat
 - Effective July 3, 2019
 - This is law (not a proposal)



FER Rumor VS Fact

Rumor:

- “FER is delayed/cancelled”

Fact:

- FER is a law in both the US and Canada, going into effect July 3, 2019.
- Confusion due to two activities:
 1. A new metric “AFUE2” is being discussed
 2. DOE issued an FER enforcement policy statement that confused a lot of people
- There is some possibility that FER might get delayed; but that has not happened yet.

We are moving forward will all launch plans.

NEVER STOPPING. NEVER SETTLING.

Coils – Patrick Van Deventer



It's Hard To Stop A Trane.®

4TXC and 4PXC model addition

- Adding a new A-width coil option for increased capacities of 2.5 and 3 ton AC/HP systems
 - 13-14 SEER up to 3 ton
 - 16/13 up to 2.5 ton
- Factory-installed TXV
- 14.5" wide, 22.5" tall – Narrow installations
- Multi-position 4TXC and upflow/downflow 4PXC-U

Ratings / Bulletin: January 2019
Production Launch: March 2019

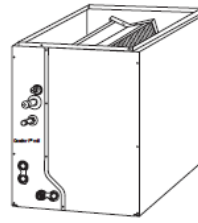

4TXC
Comfort™ Coil

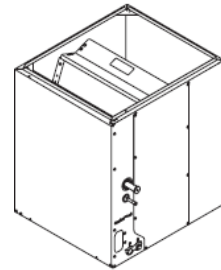

4PXC-U
Comfort™ Coil

Table COIL-1-A — Aluminum High Efficiency Staged System Cased Convertible Coils (Upflow/ Downflow/ Horizontal Left or Right) R-410A Refrigerant

| Model Number | Cooling Capacity Range (Tons) | Coil Type | Refrigerant Control | Outlet Dim. (in.) W/H x D | Overall Dim. (in.) H x W x D | Shipping Weight (lbs.) | Line Size OD Gas | Line Size OD Liq. |
|-----------------------|-------------------------------|-----------|---------------------|--|------------------------------|------------------------|----------------------------------|----------------------------------|
| 4TXCA002DS3HCA | 1.5 - 2.0 | A | TXVNBⓈ | 12 ³ / ₄ x 19 ³ / ₈ | 17.5 x 14.5 x 21.5 | 42 | ³ / ₄ | ³ / ₈ |
| 4TXCA032DS3HCA | 1.5 - 3.0 | A | TXVNBⓈ | 12³/₄ x 19³/₈ | 22.5 x 14.5 x 21.5 | 46 | ³/₄ | ³/₈ |
| 4TXCB003DS3HCA | 1.5 - 3.0 | A | TXVNBⓈ | 15 ³ / ₄ x 19 ³ / ₈ | 17.5 x 17.5 x 21.5 | 50 | ³ / ₄ | ³ / ₈ |
| 4TXCB004DS3HCA | 2.0 - 3.5 | A | TXVNBⓈ | 15 ³ / ₄ x 19 ³ / ₈ | 22.5 x 17.5 x 21.5 | 58 | ⁷ / ₈ | ³ / ₈ |
| 4TXCC005DS3HCA | 2.0 - 4.0 | A | TXVNBⓈ | 19 ¹ / ₄ x 19 ³ / ₈ | 22.5 x 21 x 21.5 | 60 | ⁷ / ₈ | ³ / ₈ |
| 4TXCB006DS3HCA | 2.0 - 4.0 | A | TXVNBⓈ | 15 ³ / ₄ x 19 ³ / ₈ | 26.9 x 17.5 x 21.5 | 65 | ⁷ / ₈ | ³ / ₈ |
| 4TXCC007DS3HCA | 3.0 - 5.0 | A | TXVNBⓈ | 19 ¹ / ₄ x 19 ³ / ₈ | 26.9 x 21 x 21.5 | 69 | ⁷ / ₈ | ³ / ₈ |
| 4TXCD008DS3HCA | 3.0 - 5.0 | A | TXVNBⓈ | 22 ³ / ₄ x 19 ³ / ₈ | 26.9 x 24.5 x 21.5 | 72 | ⁷ / ₈ | ³ / ₈ |
| 4TXCC009DS3HCA | 3.5 - 5.0 | A | TXVNBⓈ | 19 ¹ / ₄ x 19 ³ / ₈ | 30.7 x 21 x 21.5 | 78 | ⁷ / ₈ | ³ / ₈ |
| 4TXCD010DS3HCA | 3.5 - 5.0 | A | TXVNBⓈ | 22 ³ / ₄ x 19 ³ / ₈ | 30.7 x 24.5 x 21.5 | 81 | ⁷ / ₈ | ³ / ₈ |

Table COIL-1-B — Aluminum High Efficiency Staged System Cased Upflow/Downflow Coils R-410A Refrigerant, Convertible to Horizontal Left or Horizontal Right with kit

| Model Number | Cooling Capacity Range (Tons) | Coil Type | Refrigerant Control | Outlet Dim. (in.) W/H x D | Overall Dim. (in.) H x W x D | Shipping Weight (lbs.) | Line Size OD Gas | Line Size OD Liq. |
|-----------------------|-------------------------------|-----------|---------------------|--|------------------------------|------------------------|----------------------------------|----------------------------------|
| 4PXCAU24BS3HAA | 1.5 - 2.0 | A | TXVNBⓈ | 12 ³ / ₄ x 19 ³ / ₈ | 17.5 x 14.5 x 21.5 | 39 | ³ / ₄ | ³ / ₈ |
| 4PXCBU24BS3HAA | 1.5 - 2.0 | A | TXVNBⓈ | 15 ³ / ₄ x 19 ³ / ₈ | 17.5 x 17.5 x 21.5 | 42 | ³ / ₄ | ³ / ₈ |
| 4PXCBU30BS3HAA | 1.5 - 3.0 | A | TXVNBⓈ | 15 ³ / ₄ x 19 ³ / ₈ | 17.5 x 17.5 x 21.5 | 47 | ³ / ₄ | ³ / ₈ |
| 4PXCCU30BS3HAA | 1.5 - 3.0 | A | TXVNBⓈ | 19 ¹ / ₄ x 19 ³ / ₈ | 17.5 x 21 x 21.5 | 49 | ³ / ₄ | ³ / ₈ |
| 4PXCAU32BS3HAA | 1.5 - 3.0 | A | TXVNBⓈ | 12³/₄ x 19³/₈ | 22.5 x 14.5 x 21.5 | 43 | ³/₄ | ³/₈ |
| 4PXCBU36BS3HAA | 2.0 - 3.5 | A | TXVNBⓈ | 15 ³ / ₄ x 19 ³ / ₈ | 22.5 x 17.5 x 21.5 | 54 | ⁷ / ₈ | ³ / ₈ |
| 4PXCCU36BS3HAA | 2.0 - 4.0 | A | TXVNBⓈ | 19 ¹ / ₄ x 19 ³ / ₈ | 22.5 x 21 x 21.5 | 56 | ⁷ / ₈ | ³ / ₈ |
| 4PXCBU42BS3HAA | 2.0 - 3.5 | A | TXVNBⓈ | 15 ³ / ₄ x 19 ³ / ₈ | 26.9 x 17.5 x 21.5 | 61 | ⁷ / ₈ | ³ / ₈ |
| 4PXCCU42BS3HAA | 2.5 - 3.5 | A | TXVNBⓈ | 19 ¹ / ₄ x 19 ³ / ₈ | 26.9 x 21 x 21.5 | 64 | ⁷ / ₈ | ³ / ₈ |
| 4PXCBU48BS3HAA | 2.0 - 4.0 | A | TXVNBⓈ | 15 ³ / ₄ x 19 ³ / ₈ | 26.9 x 17.5 x 21.5 | 61 | ⁷ / ₈ | ³ / ₈ |
| 4PXCCU48BS3HAA | 3.0 - 5.0 | A | TXVNBⓈ | 19 ¹ / ₄ x 19 ³ / ₈ | 26.9 x 21 x 21.5 | 64 | ⁷ / ₈ | ³ / ₈ |
| 4PXCDU48BS3HAA | 3.0 - 5.0 | A | TXVNBⓈ | 22 ³ / ₄ x 19 ³ / ₈ | 26.9 x 24.5 x 21.5 | 68 | ⁷ / ₈ | ³ / ₈ |
| 4PXCCU60BS3HAA | 3.5 - 5.0 | A | TXVNBⓈ | 19 ¹ / ₄ x 19 ³ / ₈ | 30.7 x 21 x 21.5 | 73 | ⁷ / ₈ | ³ / ₈ |
| 4PXCDU60BS3HAA | 3.5 - 5.0 | A | TXVNBⓈ | 22 ³ / ₄ x 19 ³ / ₈ | 30.7 x 24.5 x 21.5 | 77 | ⁷ / ₈ | ³ / ₈ |

4PXC-D Model Consolidation

Slimming down the 4PXC-D Dedicated Downflow coil lineup to optimize coverage and minimize SKU's

- *Keeping 6 models, phasing out 7*
- *Coil design optimized for downflow performance*
 - *16+ SEER with Downflow furnaces*
 - *Higher HSPF, SEER, EER, Capacity*
- *Added over 1200 Ratings with remaining 4PXC-D models and 4PXC-U models in downflow to maintain ratings*
- *Bulletin forthcoming*

| Model | Status | Capacity | Width | Height |
|-----------------------|-------------|----------------|----------|--------------|
| 4PXCAD24BS3HDA | Phase out | 1.5-2.0 | A | 17.5" |
| 4PXCBD24BS3HDA | Phase out | 1.5-2.0 | B | 17.5" |
| 4PXCBD30BS3HDA | KEEP | 1.5-2.5 | B | 17.5" |
| 4PXCBD36BS3HDA | KEEP | 2.0-3.0 | B | 22.5" |
| 4PXCBD42BS3HDA | KEEP | 2.5-4.0 | B | 26.9" |
| 4PXCBD48BS3HDA | Phase out | 2.5-4.0 | B | 22.5" |
| 4PXCCD30BS3HDA | Phase out | 2.0-2.5 | C | 17.5" |
| 4PXCCD36BS3HDA | Phase out | 2.0-3.0 | C | 22.5" |
| 4PXCCD42BS3HDA | KEEP | 2.5-4.0 | C | 26.9" |
| 4PXCCD48BS3HDA | Phase out | 3.0-4.0 | C | 26.9" |
| 4PXCCD60BS3HDA | KEEP | 3.5-5.0 | C | 30.7" |
| 4PXCDD48BS3HDA | Phase out | 3.0-4.0 | D | 26.9" |
| 4PXCDD60BS3HDA | KEEP | 3.5-5.0 | D | 30.7" |

Coil Readiness Plan - Q1 2019

Our Coil business is growing!

- *Planning for over 90,000 coils in stock for pre-season 2019*
- *We need our partners to stock up early to optimize coil availability next season*
 - *Quick response for pre-season replacement jobs*
 - *Shorten lead times during peak months*

Sales plan details

- *All coil families qualify*
- *+60 day terms for 5% YoY order increase in Q1*
- *Your Regional Manager will reach out to you soon*



NEVER STOPPING. NEVER SETTLING.

Geothermal – Jay Ayers



It's Hard To Stop A Trane.®



Geothermal Product Line Transitions to WaterFurnace

Starting in January 2019, Envirowise® Trane® and Envirowise American Standard® equipment will no longer be supplied by Ingersoll Rand. We will transfer full control of the product offering, materials, manufacturing, sales, and distribution to WaterFurnace, which has been our OEM supplier for these products since 2011. The equipment will no longer carry the Trane or American Standard brands, or the Envirowise label.

The last day for dealers and distributors to order Trane or American Standard geothermal equipment through the Ingersoll Rand Oracle system will be December 14, 2018. No orders will be accepted through our system after that date. WaterFurnace and Ingersoll Rand are working closely together to ensure a smooth transition over the next two months. You will be contacted by your account representative with information on the steps and process to transition your geothermal orders to WaterFurnace beginning January 2, 2019.

Ingersoll Rand and WaterFurnace leadership agreed that the transition is in the best interest of our geothermal equipment customers and businesses. The move aligns with the vision to Deliver the Best Experience to our customers, and will facilitate continuity of geothermal products for Trane and American Standard distributors and dealers by offering access to WaterFurnace-owned brands.

Jay Ayers, Ingersoll Rand Geothermal Product Manager, will lead the transition team through the end of February 2019, and will advocate for our channel. The offer for an alternate brand is voluntary, and has no requirement to accept, nor guarantee of availability.

Thank you for your understanding and acceptance of the decision to transition the ground source heat pump business, and thank you in particular for allowing us to earn your business over the past 7 years. We have an excellent OEM partner in WaterFurnace, which is prepared to service your geothermal business needs in 2019 and beyond.

NEVER STOPPING. NEVER SETTLING.

Indoor Air Quality – Jay Ayers



It's Hard To Stop A Trane.®

Recap of 2018 Product Additions in IAQ

- QuikBox Cabinet and Media Filter
 - Launched April - See eTPB1811 on DealerNet
 - Replaces TFM Perfect Fit Cabinet sizes with exception of 3 downflow furnace sizes and the 14.5” upflow size which are phased out
 - Two new sizes- 18.5” for TEM air handler and 16.5” for S Series furnace
- QF130V Inline Ventilator w/ Intelligent Logic
 - Launched April - See Bulletin eTPB1813 on DealerNet
 - First Inline ventilator fan with *full ECM Motor* that is 62.2 Ventilation Compliant. No balancing dampers required
 - Intelligent “Q” Controller with adjustable lockouts for temperature and humidity with timed sampling, allowing intermittent ventilation for code compliancy
- 70V Dehumidifying Ventilator
 - Launched Nov. 2017 – See eTPB1723 on DealerNet
 - Use for fresh air ventilation in humid climates or in high performance homes
 - Use as a stand alone or ducted 70 ppd dehumidifier for indoor humidity control

Envirowise
INDOOR AIR SYSTEMS



New Models added to Dehumidifier Line Up

Trane is pleased to announce the launch of 4 new models of horizontal dehumidifiers with capacities from 98 pints per day up to 205 pints per day.

- EDHUM0981H1MDAA
- EDHUM1051H1MDAA
- EDHUM1551H1MDAA
- EDHUM2051H1MDAA



NOTE: These products will be launched under the Envirowise product label. This is a single sku product offering with no brand specific badging. This opens up new sales channels, reduces inventory requirements, and offers the same quality product and brand standards as all Trane products.

Product Features and Specifications Include:

- Exclusive XT coil technology means higher efficiency humidity removal rates than standard units
- All Units are Energy Star rated
- All units come with optional ventilation capability to meet ASHRAE 62.2 Ventilation requirements
- Units can be ducted to and wired to operate with HVAC system or can used independently of HVAC system with internal blower and wired control
- Units come standard with MERV 11 filter for improved indoor air quality

IMPORTANT DATES

First Order: Immediately

First Ship: Immediately

Sales Literature: 72-1313-02

Technical Literature:

- 18-HE103D1-1-EN
- 18-HE105D1-1-EN
- 18-HE106D1-1-EN
- 18-HE107D1-1-EN

Pricing: Available on ComfortSite

NEVER STOPPING. NEVER SETTLING.

Controls – Karl Mutchnik



It's Hard To Stop A Trane.®

Connected Controls

- XR724
 - target availability February 2019
- XL824, 850 and 1050 - version 5.4 software upgrade
 - available on Comfortsite for download on or about 12-7-2018
 - 1050 and zoning - features 4 sensors per zone

Non-Connected Thermostats – new models in 2019

- 803, 802, 800
 - replacement 303, 302 (800 to phase out)
 - programmable touchscreen control
 - common preferred, not required with batteries
 - target availability late December 2018/January 2019
- 602, 600
 - replacement 203, 202 programmable push button control
 - common preferred, not required with batteries
 - target availability January/February 2019
- 401, 200
 - replacement for 401, 200 will feature non-programmable push button control
 - common preferred, not required
 - target availability April/May 2019
- 402 – no change, continue to offer in line up

NEVER STOPPING. NEVER SETTLING.

Residential Packaged-Charles Trammell



It's Hard To Stop A Trane.®

Opportunity: Variable Speed

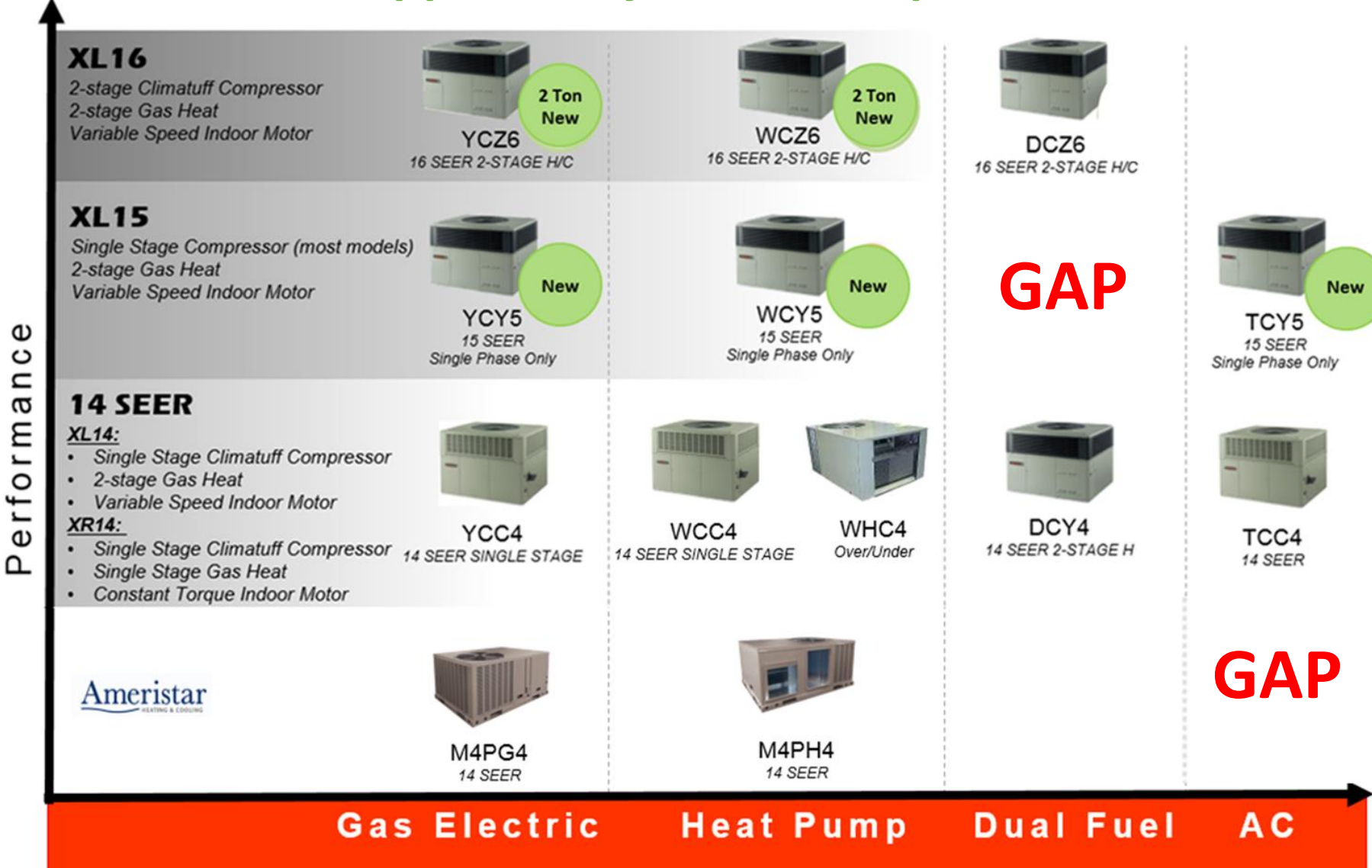



- Do not lose on price!
- Convertible GE
- Horizontal HP
- 3-5 Tons
- 14 SEER (R-410A)
- Engineered in the USA
- ARI Certified
- ETL Listed

- 5-Year Base Limited Parts Warranty
- 10-Year Registered Parts Warranty

new



**New 2-Ton XL 16 Packaged Models
(Heat Pump & Gas Electric only)**

!! Available Now !!

**Available Now
!!! for XR and XL Impack !!!
Package Families**

CleanEffects™ AIR CLEANER

Trane has always been an industry leader in home comfort. Now, we're setting a new standard for clean indoor air with the revolutionary Trane CleanEffects™, the world's most effective whole-house air filtration system.

- Removes up to 99.98% of allergens
- Industry-leading clean air delivery rate
- Low operating cost, no filters to buy



new

Available: **April 2019!!!**

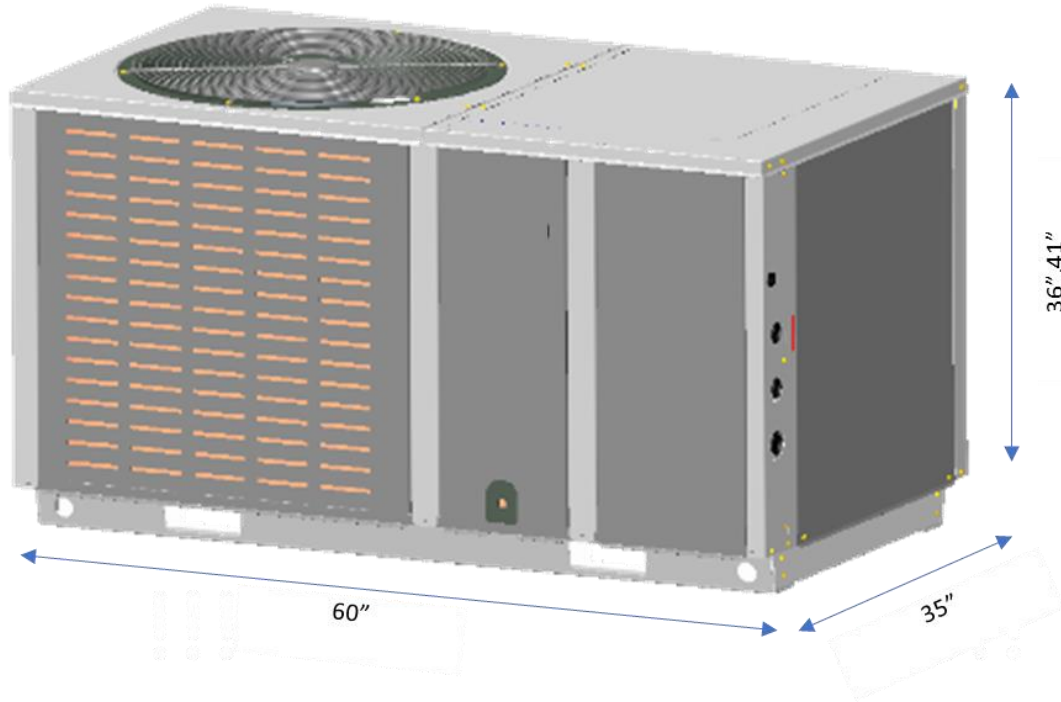

Low Cost AC:

- Manufactured in Vidalia, GA
- 2-5 Ton, 14 SEER
- Convertible
- Supports Modular/ Mfg. Homes
 - Square to Round
 - High Static Blower System
 - Neighbor-Friendly Sound
- Fits Low Lot Lines

Matt Bynum, Res Channel LCU Product Manager

- 5 years with Ingersoll Rand
- Previously Project Pricing Manager
- Started role as Product Manager – LCU Splits & Packages October 1st
- Really enjoys data and analytical problem solving
- Works best in team collaboration
- Education – MBA Louisiana State University
- Married with 2 girls (3 years and 10 months)



NEVER STOPPING. NEVER SETTLING.

LCU Packaged – Matt Bynum



It's Hard To Stop A Trane.®

Hurricane Michael hit the Lynn Haven Plant on 10/10/18



Ingersoll Rand focused on its people first



 **Tara Daneau**
October 17 at 4:17 PM

As we pulled away today, I started to cry just looking in the back seat at all the supplies, food, and necessities we was just given by Trane. We are forever grateful. I'm proud to work for a company that is so caring and supportive.



Lynn Haven Recovering from Hurricane Michael



Most Recent Lynn Haven Products Update

- **PRECEDENT UPDATES:**

- As previously announced, lead times for Precedent are extending to 35 days (from 25 days).
 - Scheduled Ship Dates (SSDs) are in the process of being updated and most will be moved out by ~2 weeks. Please check Comfortsite / ASDealernet regularly for updates, as any blank SSDs are in the process of being fixed.
 - Specifically for **Precedent high efficiency units 7.5T and above**, that lead time is extending to 40 days, and the factory is unlikely to improve dates due to the significant open backlog. Please refrain from new orders that are contingent on the factory improving the published lead time.
- We expect the lead times to decrease over the upcoming weeks as our significant material constraints are alleviated; until then, our ability to commit to specific ship dates is limited.
- We expect to be back at normal stock unit levels by late Q1 2019 and are on track to operate at pre-storm levels prior to the busy season Q2 2019.

- **IMPACK UPDATES:**

- There are fewer material outages on Impack and production rates are gradually increasing, which means that Scheduled Ship Dates (SSDs) are more likely to stay the same or improve. Items with the longest lead times continue to be the gas-electric and duel-fuels.
- We expect to be back at normal stocking levels by late Q1 2019

Lynn Haven Order FAQs

- **If a customer placed an order and wants to cancel because it's taking too long, how are we handling that?**
- Please be in constant communication with Customer Support if you are going to cancel an order. They can talk to you about the status of your order and will handle waiving of cancellation fee where applicable. We want to especially avoid cancellations for units that have already been built or in the process of being built given the tight supply.
- **My ship date seems to be moving around. How can I feel confident this is accurate?**
- Our production situation remains “fluid.” Scheduled production currently does not have a 100% chance of actually being produced that day due to material outages and manpower availability. Our production schedule is being updated frequently to adjust for this variance, resulting in “moving” ship dates. When a line is “reserved” in the system, you can feel most confident in the date.

Lynn Haven Order FAQs

- **If I see a ship date moving out to a later date, what does that mean?**
- If you see your ship date move out a week or more, it likely means that a material component isn't available and the factory is waiting on it. Please contact your Customer Service Representative to confirm.
- If the ship date moves just a few days, it likely means the unit didn't get produced that day and production will get pushed to the next 1-3 days. Please contact your Customer Service Representative to confirm.

3-5T Foundation – Available as a Substitute for 3-5T Precedent

<https://traneconnection.com/news-articles/3-5-ton-foundation-are-you-losing-money/>

the Connection



Are You Losing Money? Advantages of the 3-5 Ton Foundation

Did you know that you are losing money anytime one of your dealers replaces a mid-'80s Carrier packaged unit with anything other than a Trane 3-5 Ton Foundation Packaged Unit? We are committed to helping you inform your dealers about the advantages of these units, and have put together a **Digital Sales Kit** full of resources that will inform, educate, and inspire. Check them out now by clicking on the links.

Why Trane 3–5 Ton Is the Ideal Replacement for Common Mid-'80s Carrier Units

- Easy, hassle-free installation—matches “through-the-base” utilities with optional kit
- Weighs less than Carrier units
- No structural analysis required
- Long-life compressors
- Tubular heat exchanger
- Microchannel condenser coil comes standard
- Reliable gas ignition system

Audio Podcast ([listen](#))

One-Page Flyer ([download](#))

Live Webinar ([listen](#))

Small Foundation Training Slides ([download](#))

eLearning Course

([IWD and Dealer view](#))

([DSO and IR view](#))

Dealer Testimonies ([watch](#))

Dealer Buying Behavior Summary: Insights & Conclusions



Most Dealers like it when they try it....

"It's straightforward, quick install, fits perfect."

→ Product is working well



....But it's not always easy to get them to try it. Trial requires:

- Active focus on pushing the product (ISS & TMs). Many don't know about it!
- ISS quoting as default, and knowing when it can be quoted (what curbs it replaces)
- Relevant price and availability



Dealer Penetration is still low, even among distributors who are selling a lot

→ Large opportunity to continue to drive awareness & adoption among existing dealer base



Dealers embracing the Foundation are the Price Seekers

- May or may not be in loyalty programs;
 - Their other "go-to" brand varies
- Implies: Opportunity exists across the dealer base



Multi-unit jobs are harder to win without 7.5 & 10T

- Most Jobs are "onesie-twowie" replacement for offices & retail.
- Will sell more 3-5T when we have Medium Sizes

3-5T Foundation: Marketing Materials

Examples of What's Working



- ✓ Encourage dealers to try despite initial resistance.
- ✓ Emphasize no curb adaptor needed & low price
- ✓ Familiar with what it replaces (have Carrier Replacement Matrix handy)
- ✓ Price gap big enough (>12%) between Foundation and Precedent
- ✓ Other features they like:
 - Same price for 460 Volt as 208/230 Volt
 - For those with 2015 IECC code (low-leak economizer with FDD): Ability to stock both standard and low-leak economizers from IR, giving you options for field accessories
- Note: While there are only 2 heat sizes (low & med), the medium capacity offering is standard with 2 stages and input/output goes up to 115,000 / 92,000.

Where we are Winning with Small Foundation:

- We are growing share
- We are not cannibalizing Precedent sales

NEVER STOPPING. NEVER SETTLING.

Air Handler – Dave Garris



It's Hard To Stop A Trane.®

New OTWH/Stud/Wall Mount Air Handler GMUV Model Family

- **Provides the shortest cabinet heights in the industry**
 - Goodman AWUF market leader, 36 inch cabinet heights
 - Current TMM: 36.5 – 39.5 heights, challenging for replacements
 - Lowest cost options based on performance and installation requirements
 - Orifice/TXV, as well as PSC and CTM motor options
 - Cooling only vs. Cooling and Heating performance
- **Targeted primarily at these market segments:**
 - Non-Owner Occupied and RNC multi-family
 - New construction and replacement opportunities
- **Delivers on IR quality & reliability with an all aluminum coil**
- **Launch timing:**
 - 4 models in production, all 8 by January 2019
 - Ameristar will remain with TMM for 2019 season
 - All aluminum version from Midea will launch Q2 2019



GMUV Product Bulletin

- Product bulletin ETPB1835 released 11/2/18
- Ratings available via download
- Pricing available
 - All 8 models, even if not in production
- GMUV has been added to existing TMM4 & TMM5 quotes
- TMM4 & TMM5 Sales Promotion
 - Reference sales promotion:
 - Trane IWD: RS-SP818T
 - Trane DSO: RS-SP842D
 - Runs from 10/29/18 thru 12/31/18



PRODUCT BULLETIN

New GMU/V Model Family OTWH/Stud Mount/Wall Mount Air Handler



Trane is pleased to announce the launch of our new all aluminum GMU/V Air Handler series. This new offering has some of the shortest cabinet heights (26-30 inches) in the industry which provides a very competitive offering for both new construction and retail replacement. These models are primarily targeted at both Residential New Construction (RNC) and Non-Owner Occupied (NOO) Multi-Family opportunities. However, the units are also approved for mobile/manufactured housing (reference unit name plate for details).

This GMU/V model family is designed for over the water heater (OTWH), stud and wall mount applications and consists of 8 SKU's. They are **front return only** and offer both factory installed orifice (Cooling Only ratings) and TXV (Cooling & Heating ratings) options. Also, these units feature factory installed electric heat in 5, 8 and 10 kW options. Plus, a mixture of PSC and ECM motors to deliver the required performance at the lowest total system cost.

All of these new models have been internally tested and meet our rigorous Trane performance testing requirements. Plus, they were designed without sacrificing serviceability or reliability. These air handlers will be produced in our Vidalia, GA manufacturing facility and carry a:

- 5 Year Non-Registered /10 Year Registered Warranty

As a result of this forthcoming launch, we will begin the phase out of the current TMM4 and TMM5 Air Handlers. Plus, we have implemented a TMM sales promotion (ref sales promo #RS-SP842D (DSO) and RS-SP818T (IWD)) to help deplete inventories during this transition. However, we are maintaining the TMM offering for Ameristar only and a new all aluminum series is planned to launch in Q2 2019.

Production on only these GMU/V models began on 10/15/18:

- GMU2APB24051SA
- GMU2APB24081SA
- GMV2APB32081SA

Additional new GMU/V models will be made available once inventory of TMM models are depleted. Goal is to have all the new models in production by 1/1/19.

Contact Info
Dave Garris— Product Manager—david.garris@iroo.com—(903) 730-4504

GMUV Air Handler Series

Competitive Overview

▪ **Best in class size and performance:**



| Manufacturer | Image | Configuration | | Ratings | | Dimensions | | |
|---------------------------------|-------|---------------|--------------|-------------------|--------------------------------|------------|-------------|-----------|
| | | Motor Type | Flow control | SEER Ratings - AC | Ratings - HP | H (in.) | W (in.) | D (in.) |
| Goodman AWUF/AWUT | | PSC | Orifice | 13 SEER | - | 36 | 20.2 - 24 | 16 - 21 |
| | | CTM | TXV/Orifice | 14 SEER | 14 SEER / 8.2 HSPF | 36 | 20.2 - 24 | 16 - 21 |
| Rheem RHAL/RHLB | | PSC | TXV/orifice | 14 SEER | - | 36 | 21.5 - 24 | 17 - 21 |
| | | CTM | TXV | 14 - 16 SEER | 15 SEER / 8.5 HSPF | 36 | 21.5 - 24 | 17 - 21 |
| ADP S Series | | PSC | TXV | 14 SEER | 14 SEER / 8.5 HSPF | 30 | 22 | 19 |
| Carrier FFMA Trane TMM4/TMM5 | | PSC | Orifice | 14 SEER | 14 SEER / 8.2 HSPF | 36.5-39.5 | 20.5 - 22 | 15 - 19 |
| | | CTM | TXV | 14 - 16 SEER | 15 SEER / 8.5 HSPF | 36.5-39.5 | 20.5 - 22 | 15 - 19 |
| First Co UC/UCX | | PSC | Orifice | 14.5 SEER | - | 40-46 | 22.1 - 28.1 | 15.1 - 21 |
| | | CTM | TXV | 16 SEER | 16 SEER / 8.5 HSPF | 40-46 | 22.1 - 28.1 | 15.1 - 21 |
| Trane GMU/GMV | | PSC/CTM | Orifice | 13 - 16 SEER | - | 26 - 30 | 22 | 19 |
| | | PSC/CTM | TXV | 13 - 17 SEER | 14 - 17 SEER Up to 9.5 HSPF | 26 - 30 | 22 | 19 |

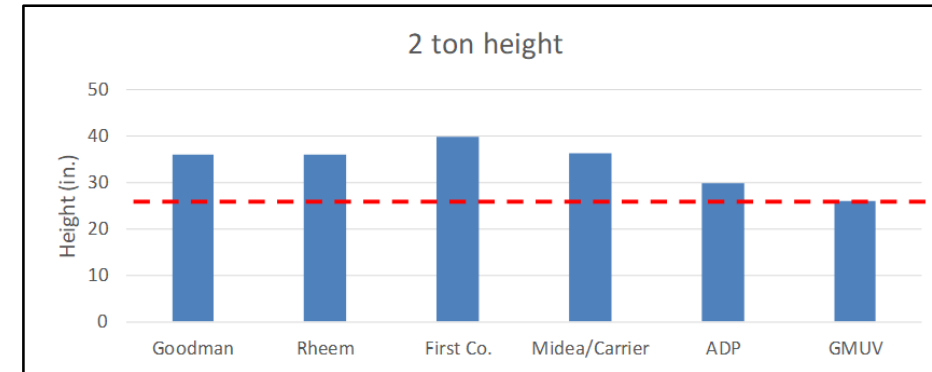

GMUV

Summary:

| Feature: | Description: |
|--|---|
| Brand: | Non-Branded Rated with Trane for 2019 season TMM will stay with Ameristar for 2019 season |
| Target Market Segments: | Multi-Family NOO and RNC |
| Coil: | All Aluminum |
| Cabinet Configuration: | Upflow, Front Return Only |
| Cabinet Material: | Non-Painted Galvanized |
| Cabinet Dimensions: | 26.0-30.0" H x 22.0" W x 19.0" D |
| Tonnage Range: | 1.5 – 3.0 Ton Model Offering, 8 SKU's Total |
| Cooling & Heating: | Supports Both Cooling Only & Cooling / Heating Applications |
| Lowest Cost Application Options: | Mix of: Factory Installed Orifice & TXV / PSC & CTM motor options |
| Factory Installed Filter Rack & Filter: | Yes |
| Ratings: | Achieves 13-17 SEER Ratings |
| Factory Installed Electric Heat: | 5,8 & 10 kW options |
| Warranty: | 5 Year Non-Registered / 10 Year Registered |

GMUV OTWH / Stud Mount Air Handler ***Service Friendly***

- **All electrical components easily accessible**
 - Remove the front control panel with 2 screws
- **Flow control external to cabinet for easy service**
 - Orifice and TXV options
- **Motor can be replaced by pivoting the slab forward**
- **Non-tooled filter replacement, easy coil cleaning**
- **Drain ports visible**
 - Easily accessible for clean-out

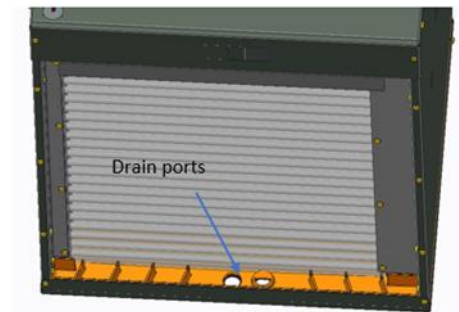
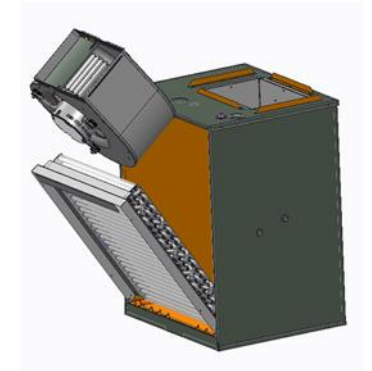
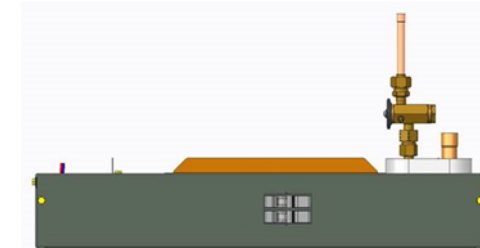
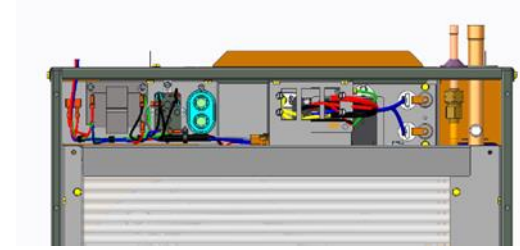

GMUV SKU Offering:

| Performance | SKU Count | New GMUV Model Number | Tonnage | Estimated Production Start Date | Potential TMM Model Cross Reference* <i>* reference actual ratings</i> | Product Dimensions | | | Factory Installed Refrigerant Control Device | Motor Type | Factory Installed Electric Heat (kW) Sizes |
|--|-----------|-----------------------|-----------|---------------------------------|---|--------------------|-------|-------|--|---------------|--|
| | | | | | | inches | | | | | |
| | | | | | | H | W | D | | | |
| GMU Upflow Only Front Return Only Cooling Only with Orifice | 1 | GMU2APB24051SA | 1.5 – 2.0 | 10/15/18 | TMM4A0A18 TMM4A0A24 | 25.40 | 22.10 | 19.30 | Orifice | PSC 3 Taps | 5 kW |
| | 2 | GMU2APB24081SA | 1.5 – 2.0 | 10/15/18 | TMM4A0A18 TMM4A0A24 | 25.40 | 22.10 | 19.30 | Orifice | PSC 3 Taps | 7.5 kW |
| | 3 | GMU2APB30081SA | 2.5 | 11/15/18 | TMM4A0B30 | 29.40 | 22.10 | 19.30 | Orifice | PSC 3 Taps | 7.5 kW |
| | 4 | GMU2AEB37101SA | 2.5 – 3.0 | 1/1/19 | TMM4A0B36 | 29.40 | 22.10 | 19.30 | Orifice | CTM 5 Taps | 10 kW |
| GMV Upflow Only Front Return Only Cooling & Heating With TXV | 5 | GMV2APB26051SA | 1.5 – 2.0 | 1/1/19 | TMM5A0B24 | 25.40 | 22.10 | 19.30 | TXV | PSC 3 Taps | 5 kW |
| | 6 | GMV2APB26081SA | 1.5 – 2.0 | 1/1/19 | TMM5A0B24 | 25.40 | 22.10 | 19.30 | TXV | PSC 3 Taps | 7.5 kW |
| | 7 | GMV2APB32081SA | 2.5 | 10/15/18 | TMM4A0B30 TMM5A0B30 | 29.40 | 22.10 | 19.30 | TXV | PSC 3 Taps | 7.5 kW |
| | 8 | GMV2AEB39101SA | 2.5 – 3.0 | 1/1/19 | TMM5A0B30 TMM5A0B36 | 29.40 | 22.10 | 19.30 | TXV | CTM 5 Taps | 10 kW |

NEVER STOPPING. NEVER SETTLING.

Ductless – Tai McKinney



It's Hard To Stop A Trane.®

NEVER STOPPING. NEVER SETTLING.

Ameristar – Brian Steckroth



It's Hard To Stop A Trane.®

NEVER STOPPING. NEVER SETTLING.

Closing Comments – Charles Trammell



It's Hard To Stop A Trane.®

- Please Delete/Remove from your calendars:
 - Product Update Call occurring on 1st Friday of every month
 - From Trane Channel Communications

Tell us what you think about the Product Update Call:

- Is it effective? Why or why not?
- What cadence? Monthly? Every other month?
- All feedback to charles.trammell@irco.com

NEVER STOPPING.

NEVER SETTling.



It's Hard To Stop A Trane.®